

magma

by Ferréol Babin
LAMP



magma one low

magma one high

magma two low

magma two high

From its earthy base to floating illuminated top, magma pulls the elements together into one sculptural centrepiece. An oblong shaped handblown glass globe shines softly onto the strong, angular ceramic base below; whose fat lava glaze bubbles and streaks to reveal its own unique character.

YEAR OF DESIGN

2018

MATERIAL

handblown glass, coloured and ceramic

COLOURS + ART. NR

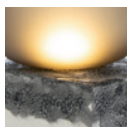

SHADE GLASS BASE CERAMIC	smoky grey acetato black	smoky grey acetato white	smoky grey acetato blue
ONE LOW	6300GB	6300GW	6300GBL
ONE HIGH	6301GB	6301GW	6301GBL
TWO LOW	6302GB	6302GW	6302GBL
TWO HIGH	6303GB	6303GW	6303GBL



SHADE GLASS BASE CERAMIC	white acetato black	white acetato white	white acetato blue
ONE LOW	6300WB	6300WW	6300WBL
ONE HIGH	6301WB	6301WW	6301WBL
TWO LOW	6302WB	6302WW	6302WBL
TWO HIGH	6303WB	6303WW	6303WBL

DIMENSIONS (mm)

ONE LOW

410 L × 410 W × 600 H

ONE HIGH

300 L × 300 W × 690 H

TWO LOW

430 L × 410 W × 460 H

TWO HIGH

380 L × 300 W × 550 H

PROCESS

Each piece is created from frosted and coloured handblown glass. The base is handmade from ceramic, and applied with a fat lava glaze. Bubbles, streaks and other variations in size and colour are part of production processes, and not defects in the design or production.

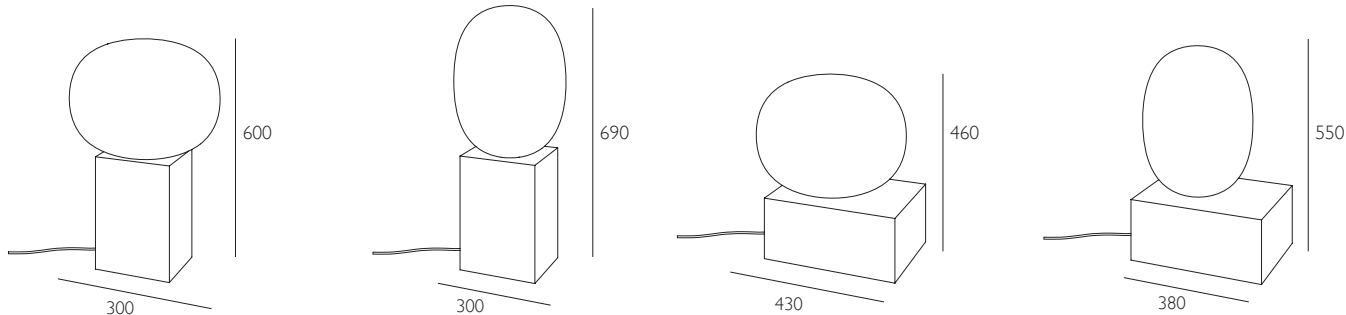

magma one low

BASE

ceramic

SHADE

handblown glass, coloured

CABLE

textile, 4000mm with foot switch and Euro-plug

DIMENSIONS (mm)

410L x 410W x 600H

LIGHT SOURCE

Bulb: LED

Bulb fitting: E27 240Volt

Dimensions (mm): Ø 80 x 120 H

Power consumption: 7 Watt

Voltage (V): 220–240; 50/60 Hz

Lifetime: 30 000 h

Radiation angle: 360°

Colour temperature: 2700 K

Lumen: 806 lm

ES: A++

Finish: warm white



UL Version

LED Filament fully dimmable

max. 7W/120V

E26, 2700 K

magma one high

BASE

ceramic

SHADE

handblown glass, coloured

CABLE

textile, 4000mm with foot switch and Euro-plug

DIMENSIONS (mm)

300 L x 300 W x 690 H

LIGHT SOURCE

Bulb: LED

Bulb fitting: E27 240Volt

Dimensions (mm): Ø 80 x 120 H

Power consumption: 7 Watt

Voltage (V): 220–240; 50/60 Hz

Lifetime: 30 000 h

Radiation angle: 360°

Colour temperature: 2700 K

Lumen: 806 lm

ES: A++

Finish: warm white



UL Version

LED Filament fully dimmable

max. 7W/120V

E26, 2700 K

magma two low

BASE

ceramic

SHADE

handblown glass, coloured

CABLE

textile, 4000mm with foot switch and Euro-plug

DIMENSIONS (mm)

430 L x 410 W x 460 H

LIGHT SOURCE

Bulb: LED

Bulb fitting: E27 240Volt

Dimensions (mm): Ø 80 x 120 H

Power consumption: 7 Watt

Voltage (V): 220–240; 50/60 Hz

Lifetime: 30 000 h

Radiation angle: 360°

Colour temperature: 2700 K

Lumen: 806 lm

ES: A++

Finish: warm white



UL Version

LED Filament fully dimmable

max. 7W/120V

E26, 2700 K

magma two high

BASE

ceramic

SHADE

handblown glass, coloured

CABLE

textile, 4000mm with foot switch and Euro-plug

DIMENSIONS (mm)

380 L x 300 W x 550 H

LIGHT SOURCE

Bulb: LED

Bulb fitting: E27 240Volt

Dimensions (mm): Ø 80 x 120 H

Power consumption: 7 Watt

Voltage (V): 220–240; 50/60 Hz

Lifetime: 30 000 h

Radiation angle: 360°

Colour temperature: 2700 K

Lumen: 806 lm

ES: A++

Finish: warm white



UL Version

LED Filament fully dimmable

max. 7W/120V

E26, 2700 K

CARE INSTRUCTIONS

Regular cleaning and maintenance is important in order to keep your pulpo product looking its best and to prolong its life. Always remove any kind of dirt as soon as possible. We recommend that you first test a small, invisible area to ensure that no colour change or damage arises to the product. Do not use materials for maintenance that contain abrasive agents or are basic, acid or organic.

GLASS CLEANING

For dusting and light cleaning of glass use a soft, dry cloth. For further cleaning gently wipe the surface with a soft cloth wrung in clean water and a non-abrasive commercial glass cleaner. Dry immediately afterwards with a soft, dry and clean cloth. Please note that bubbles, streaks and other variations in size and colour are part of the production process, and not defects of the design or production of handmade glass.

CERAMIC CLEANING

For dusting and light cleaning of ceramic use a soft, dry cloth. For further cleaning gently wipe the surface with a soft cloth wrung in clean warm water. Dry immediately afterwards with a soft, dry and clean cloth.